

Form Service & Warranty Claim

DT Swiss WHEELS

Please service! This is a warranty claim!

Contact Distributor / Dealer:

name distributor / dealer:
ZIP / address:
country:
phone:
fax:
e-mail:

Sales receipt enclosed?

yes
 no

In case the rework cannot be done under warranty, do you want us to contact you for an estimation of cost prior to service the product?

yes
 no

wheel model (e.g. M1600 front, EX1750 rear etc.):
serial number rim: _____ serial number hub: _____

Please describe precisely the wheel's failure by marking the box(es).

- bad sticker quality
- deformation (ex works, misuse etc.)
- coating damage / corrosion
- cracks on spoke holes / valve hole / rim well
- bad welding / joint
- broken / damaged / cracked hubshell
- bearing play / worn bearings
- coating damage / corrosion
- free wheel system damage (Star Ratchet or 2-Pawl system)
- strange noise while riding (creaking etc.)
- others _____

Mark spot of failure in drawing to speed up your service! Thank you!

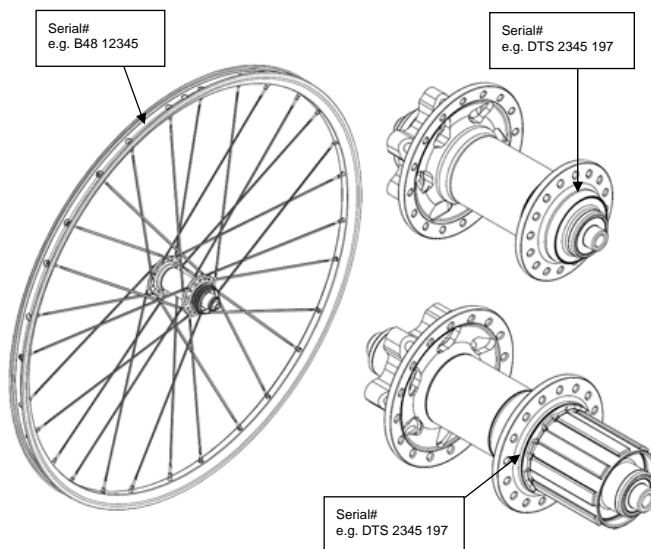

NOTE:

- One complete Service & Warranty Claim form must be added per service / warranty claim!
- The DT Swiss Service Center will reject incomplete Service & Warranty Claims (e.g. missing sales receipt etc.)!
- For further information please read the DT Swiss Owners Manual of this product concerning DT Swiss Warranty regulations or visit www.dtswiss.com.